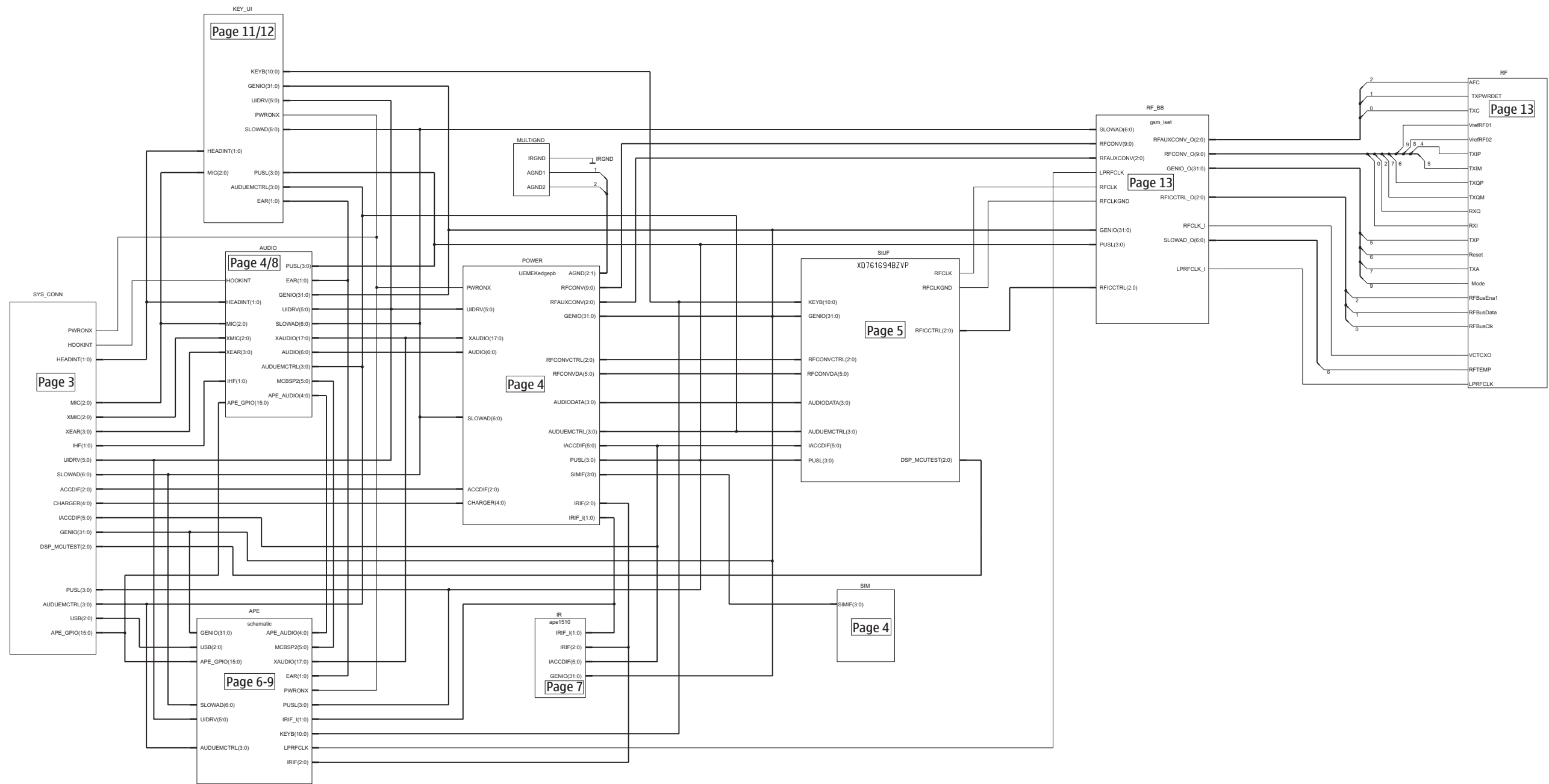
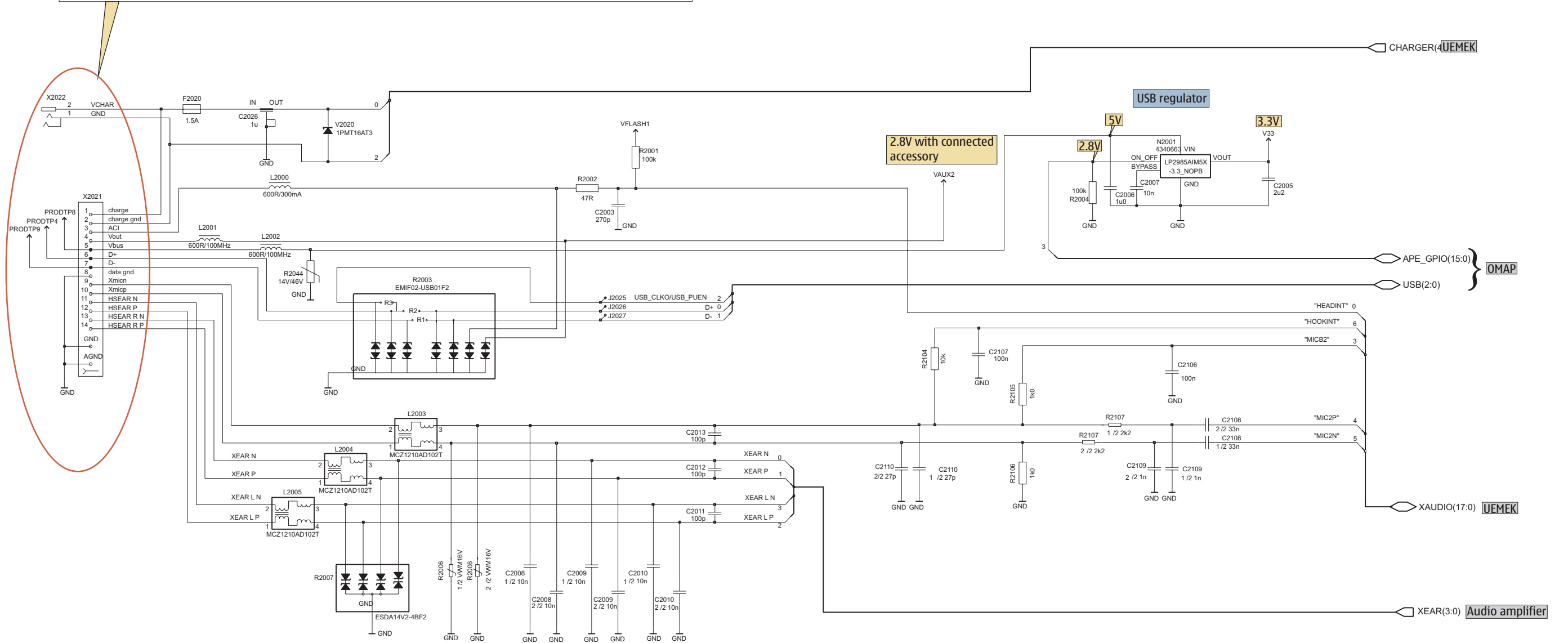
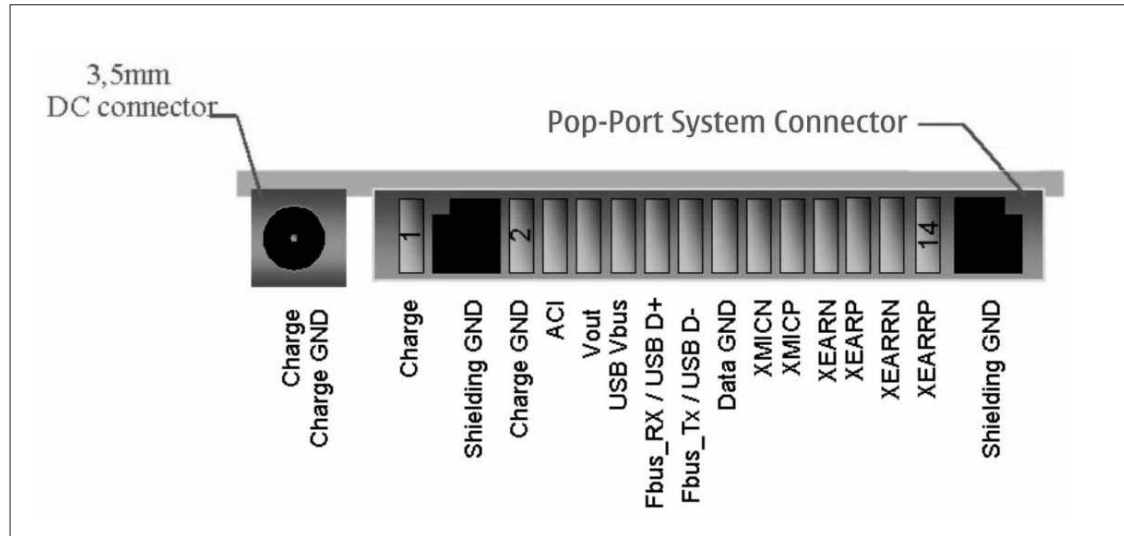

Table of Contents	Page No
DCT-4 common baseband	2
System connector, audio	3
UEMK, SIM, Zocus	4
StUF (Stacked UPP & Flash)	5
APE connection overview	6
OMAP, IRDA, MMC, APE power supply	7
Audio DAC, audio amplifier	8
Bluetooth	9
UI flex connector	10
Flex foil	11
QWERY keyboard	12
RF part	13
Signal overview	14
Component finder, UI	15
Component finder, engine module	16

DCT-4 common baseband



System connector, audio





StUF (Stacked UPP & Flash)

StUF = Stacked UPP & Flash

Pulses between 0V and 1.8V in normal mode  
1.8V in local /test mode

RF-part, OMAP, System connector

GENIO(31:0)

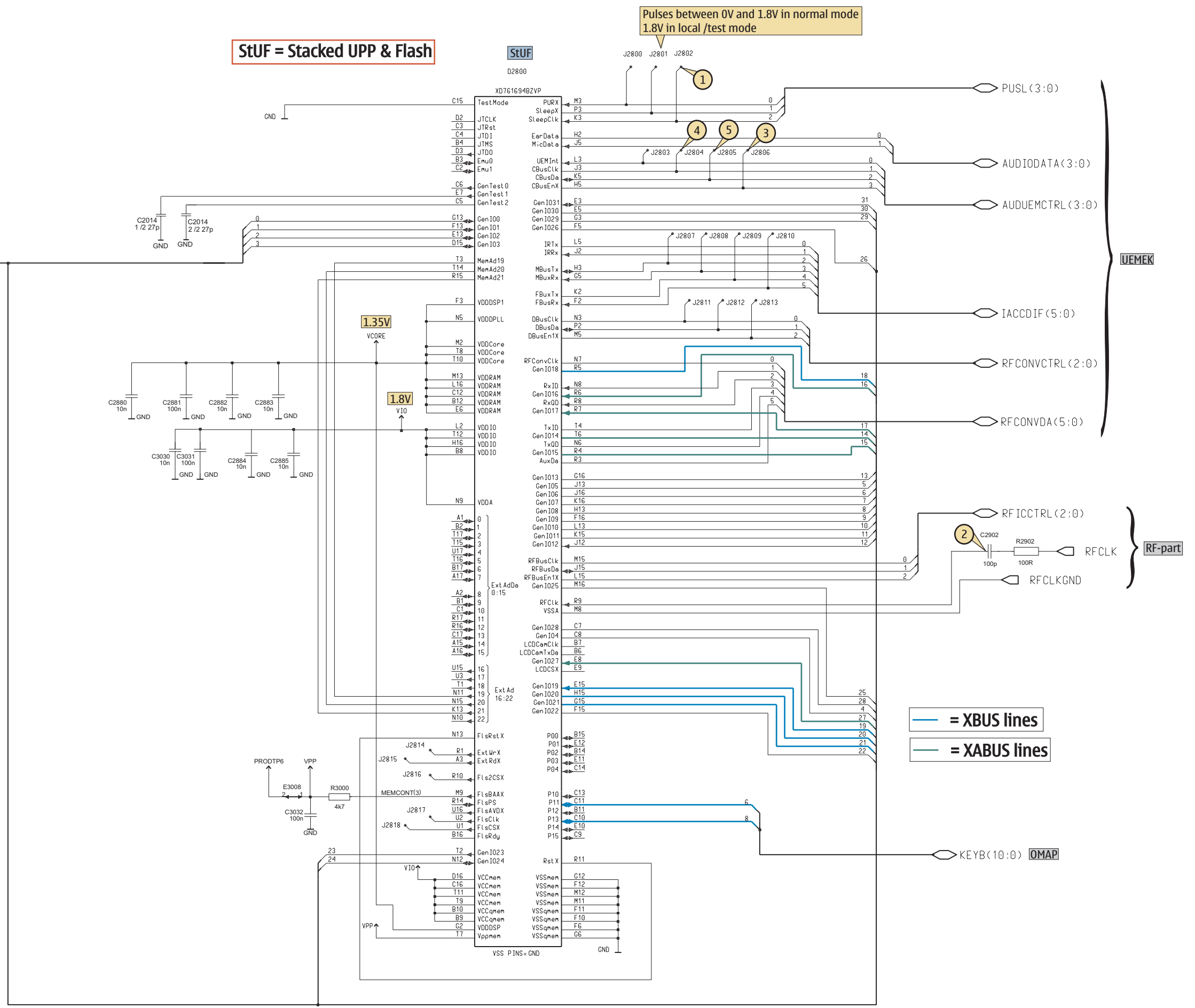

APE connection overview

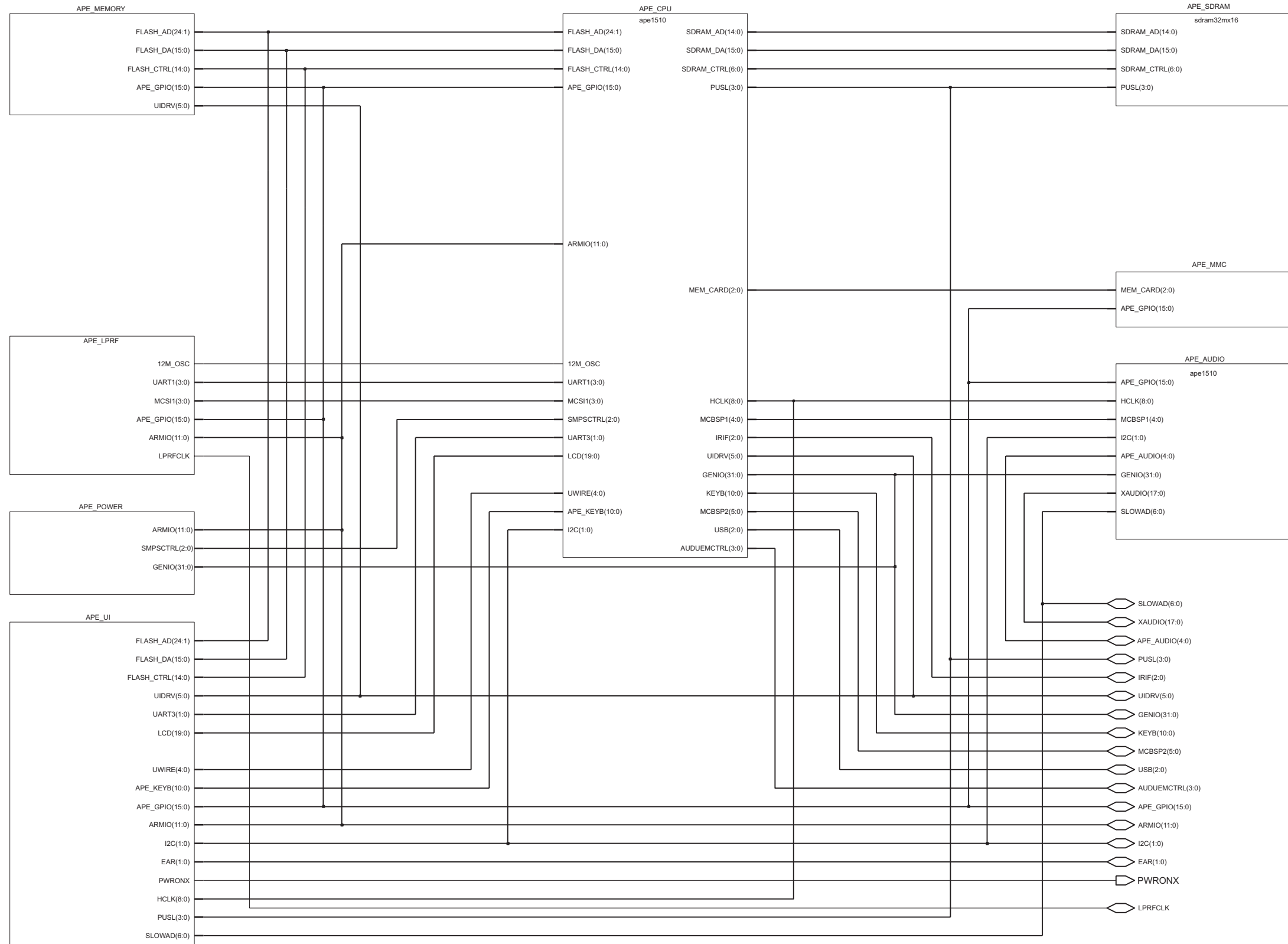

OMAP, IRDA, MMC, APE power supply

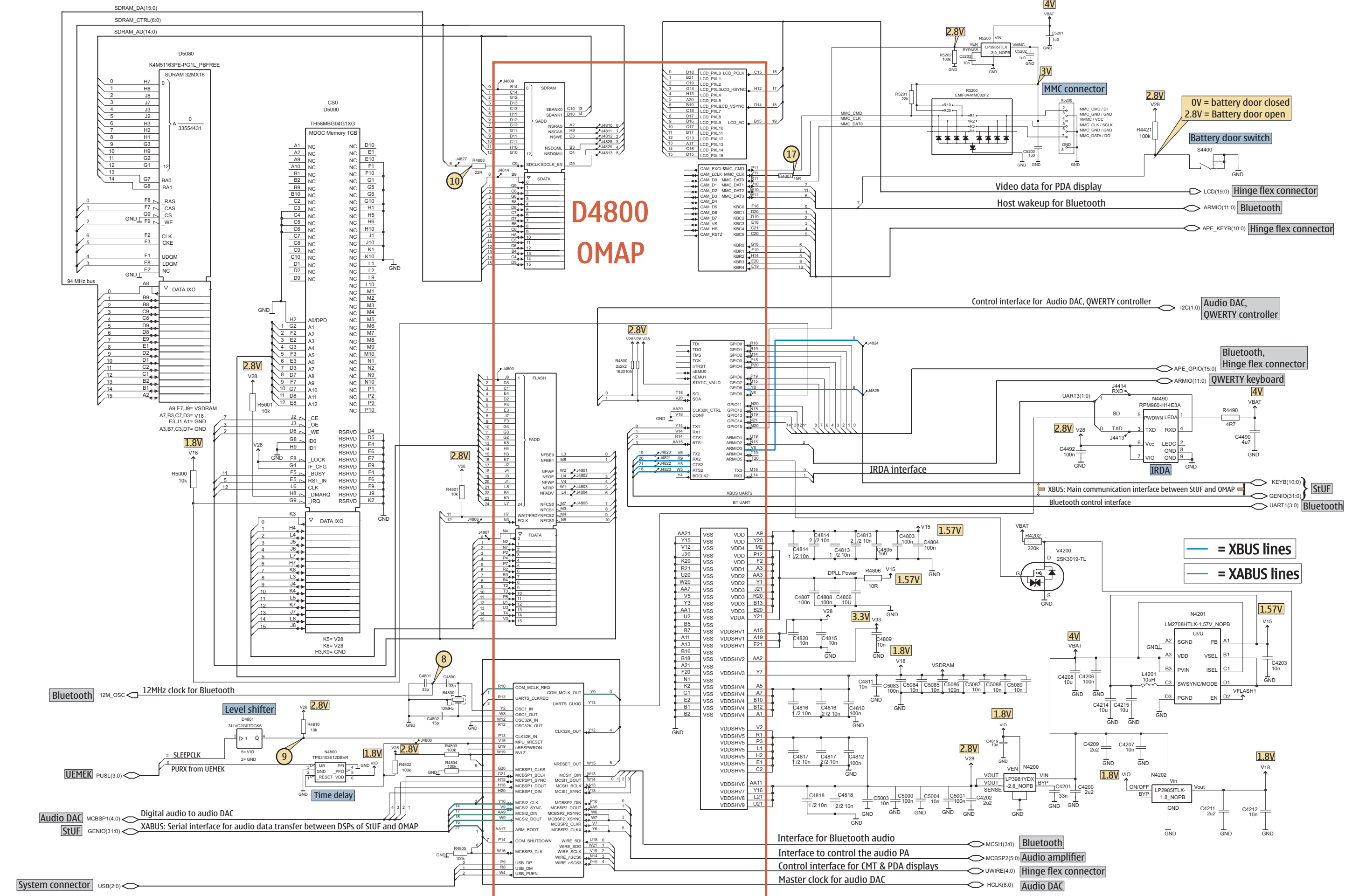

Audio DAC, audio amplifier

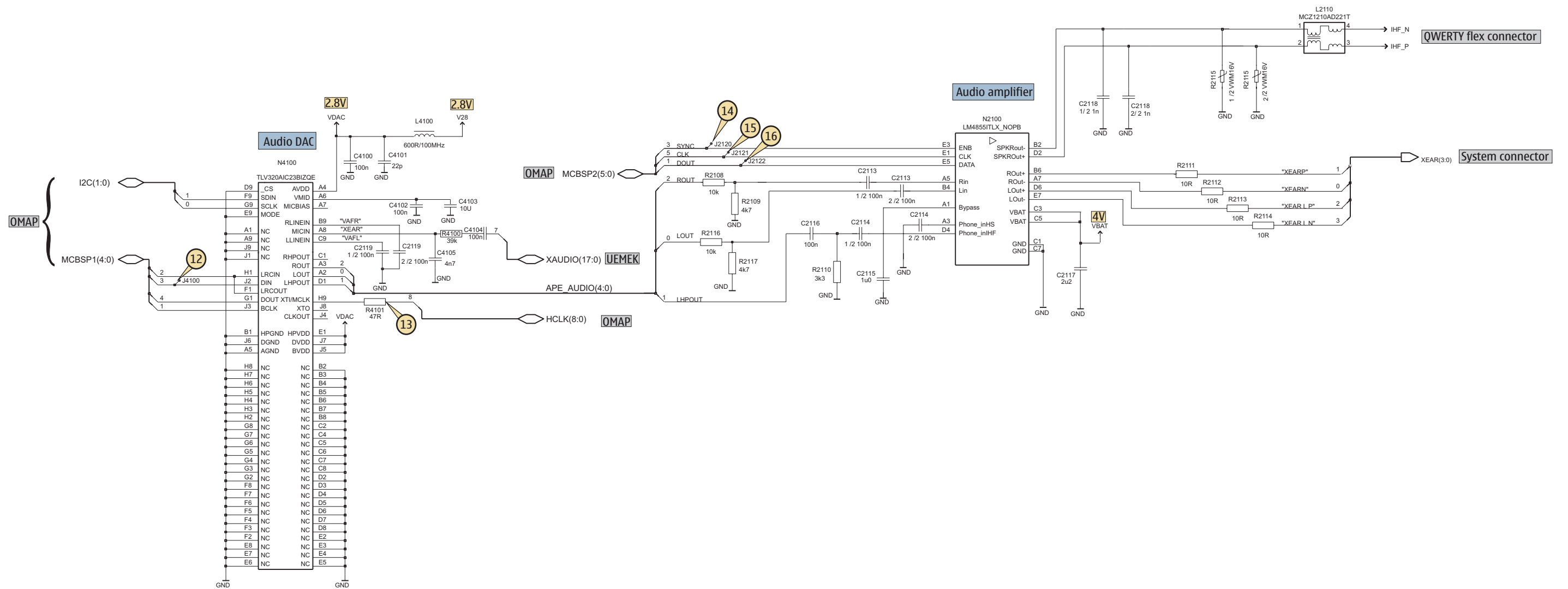



Bluetooth

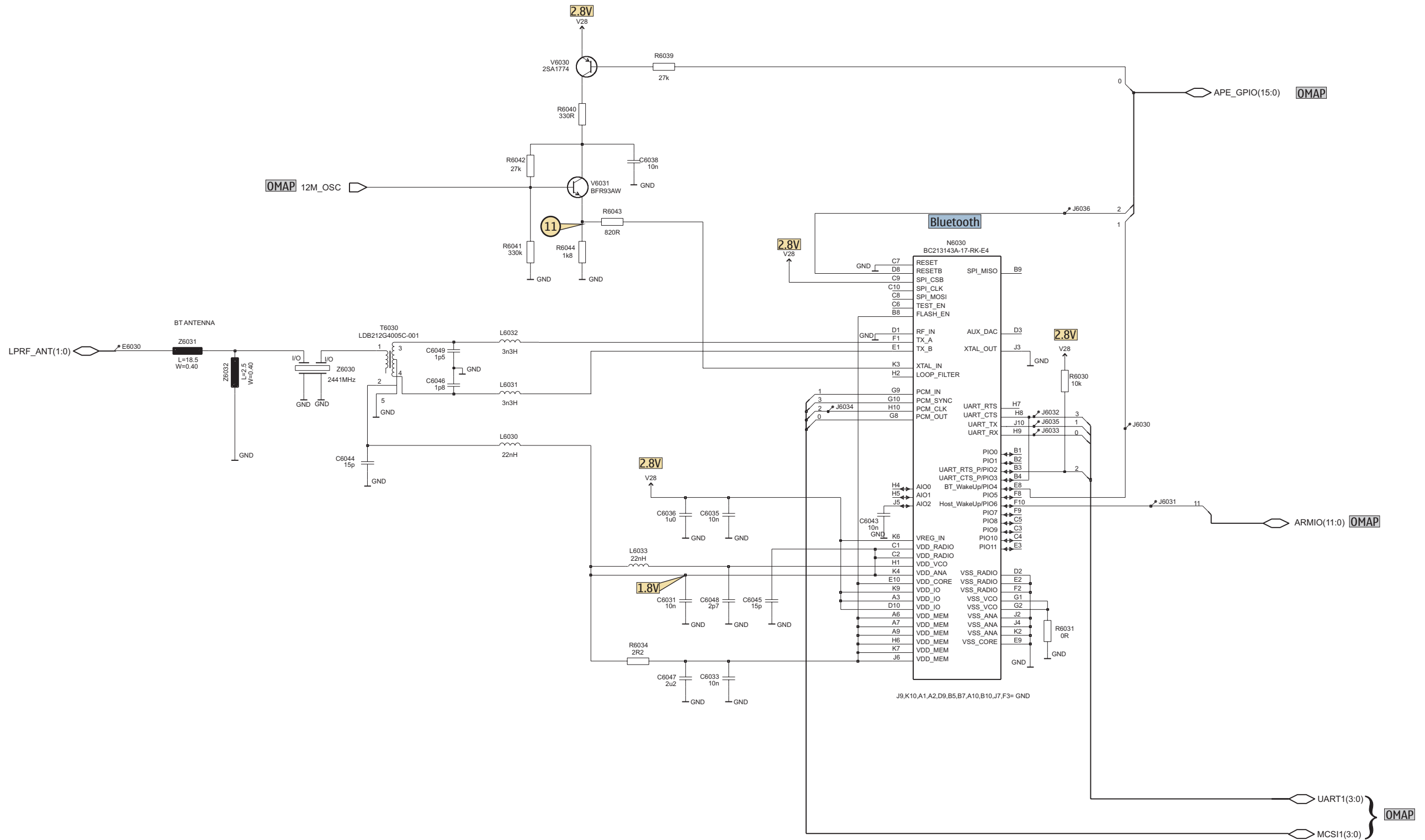

UI flex connector

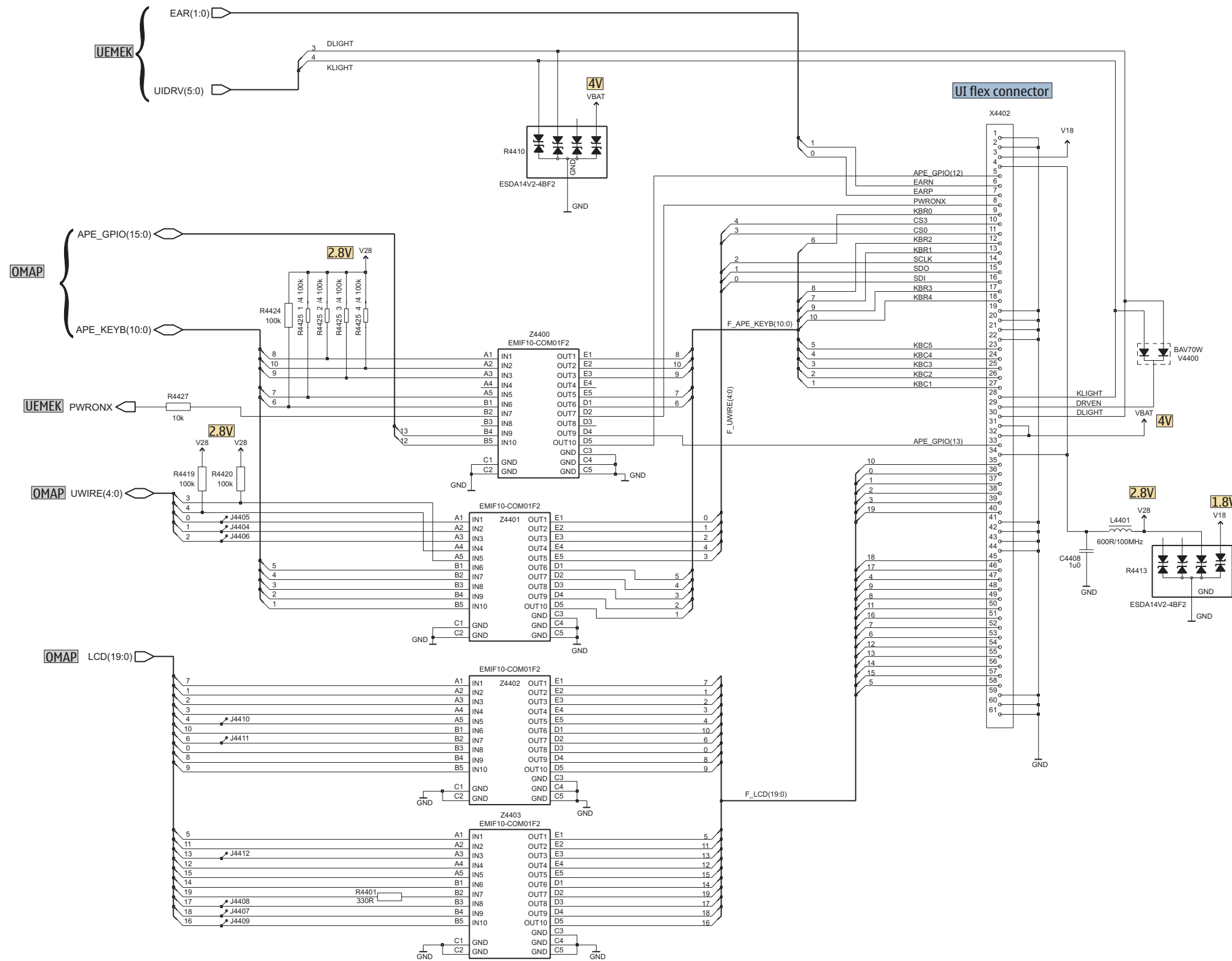

Flex foil

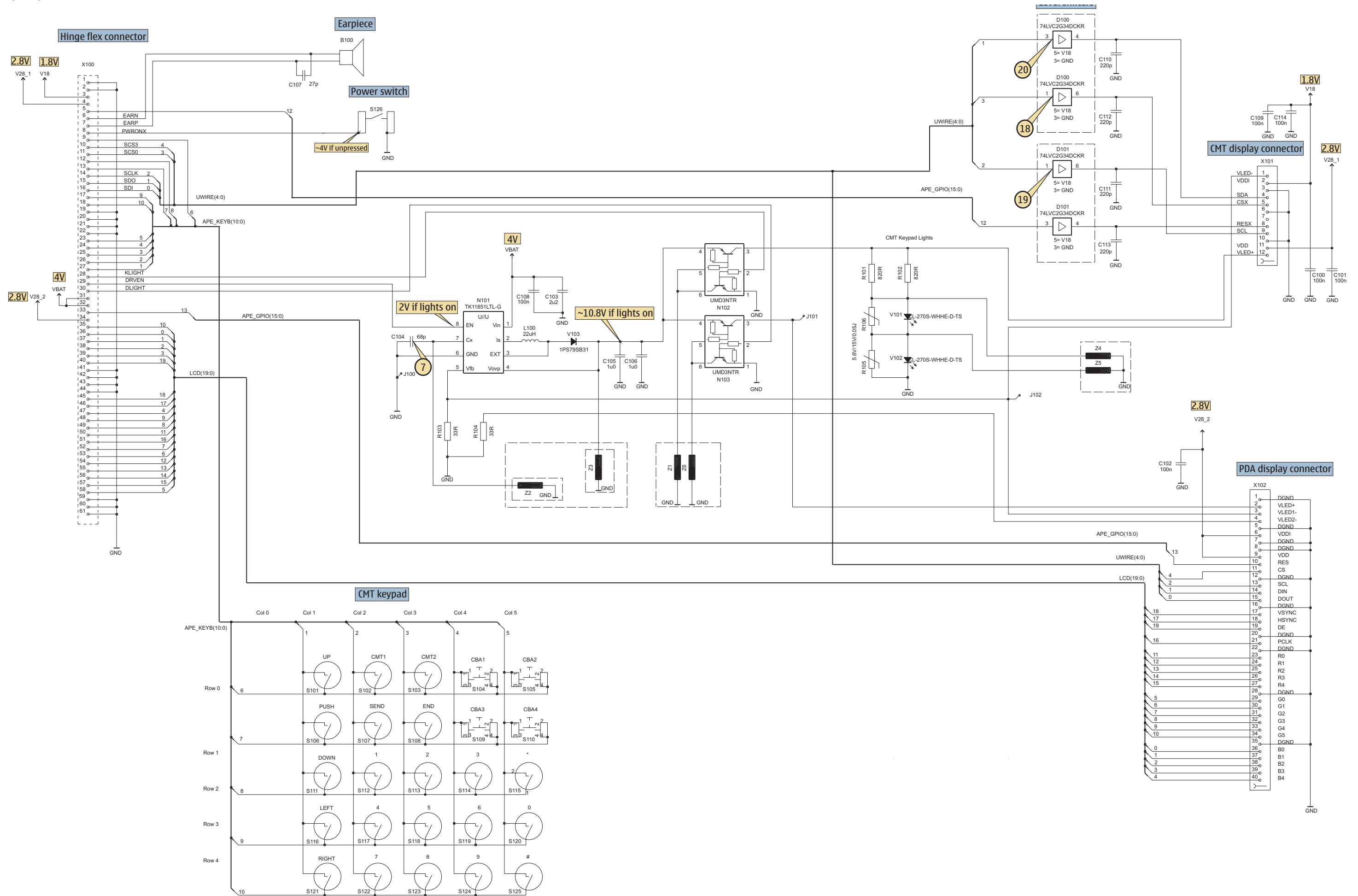



RF part

	Vc1	Vc2	Vc3
EGSM RX	-	-	-
GSM1800 RX	-	-	-
GSM1900 RX	-	2.7Vpp	-
EGSM TX	-	-	2.7Vpp
GSM1800 TX	2.7Vpp	2.7Vpp	-
GSM1900 TX	2.7Vpp	2.7Vpp	-

Band	Channel	RX	VCO/RX	VC/RX	TX	VCO/TX	VC/TX
EGSM 900	37	942.4MHz	3769.6MHz	~2.76V	897.4MHz	3589.6MHz	~2.03V
GSM 1800	700	1842.8MHz	3685.6MHz	~2.43V	1747.8MHz	3495.6MHz	~1.63V
GSM 1900	661	1960MHz	3920MHz	~3.32V	1880MHz	3760MHz	~2.73V

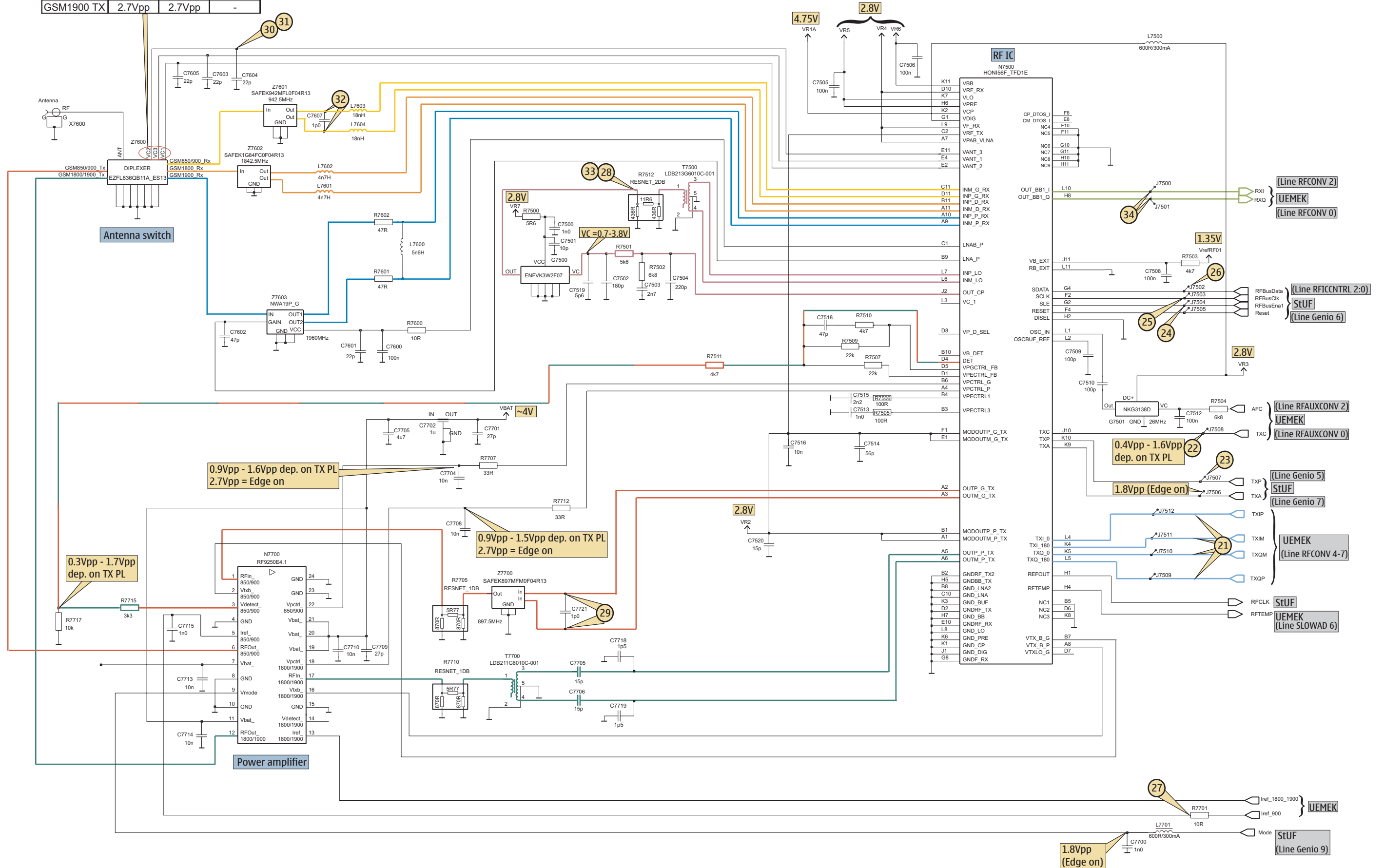

Signal overview

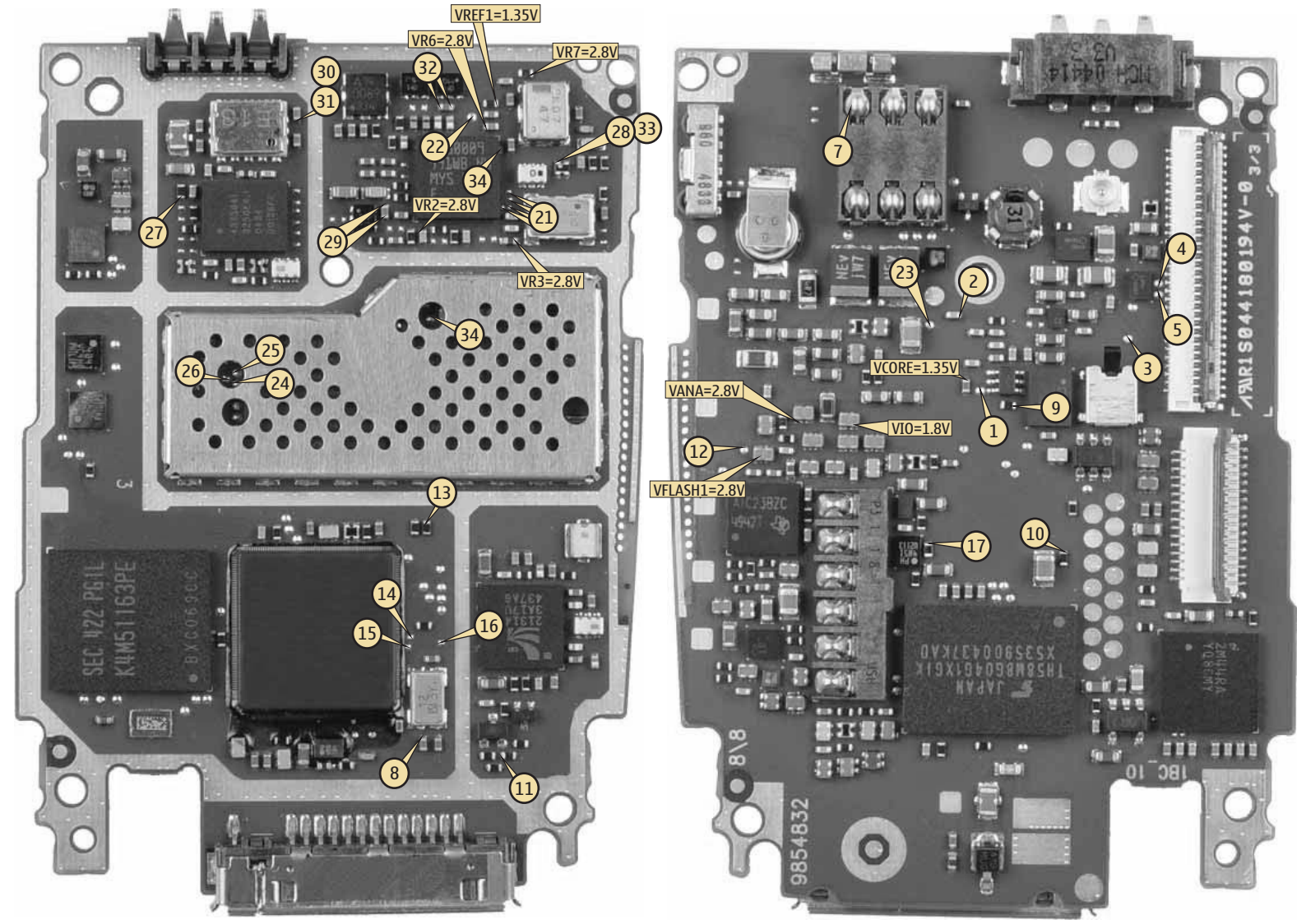
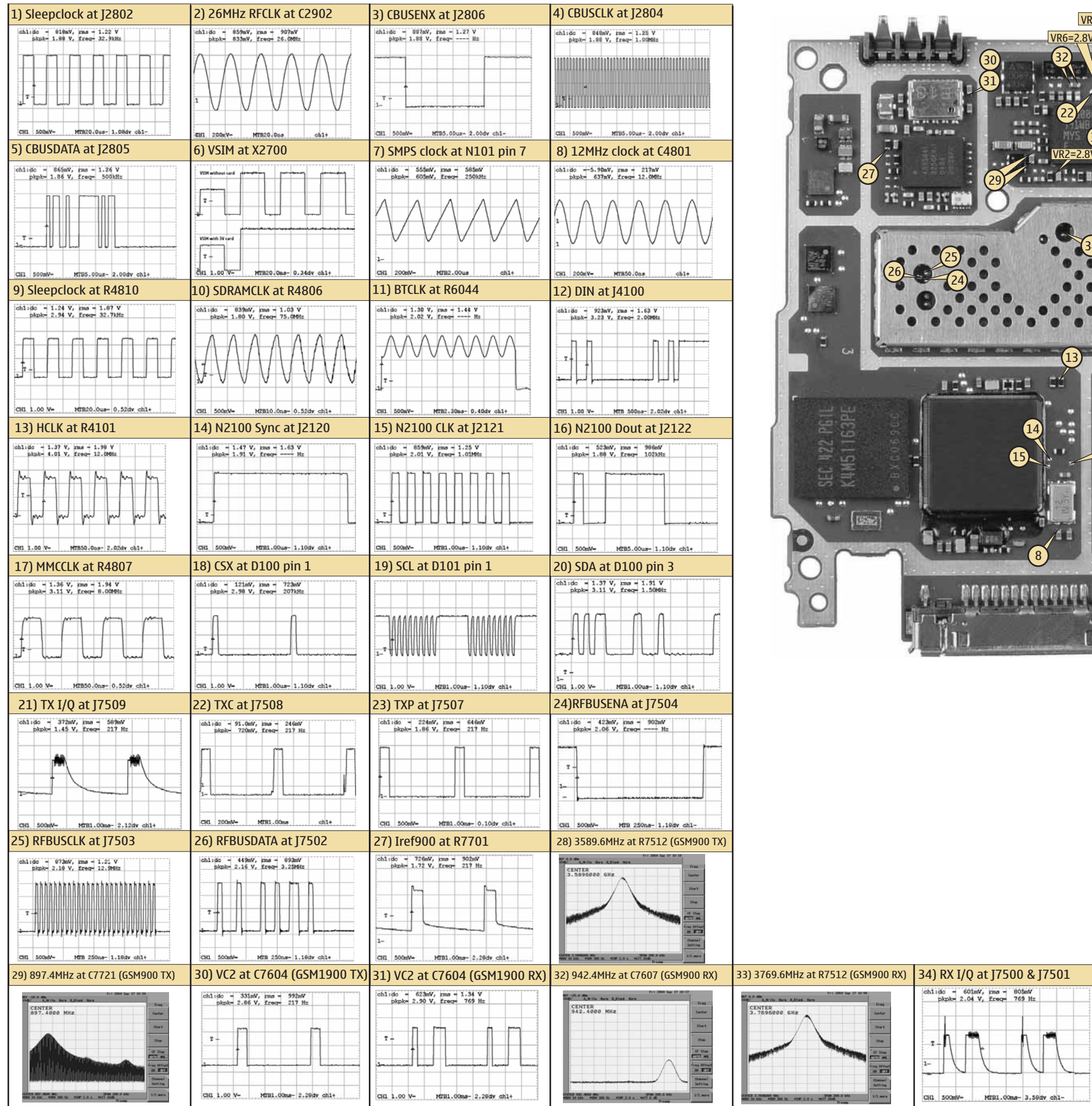

Component finder, UI

C
C013 A8
N
N010 A8
R
R011 A9
R012 A9
S
S100 X3

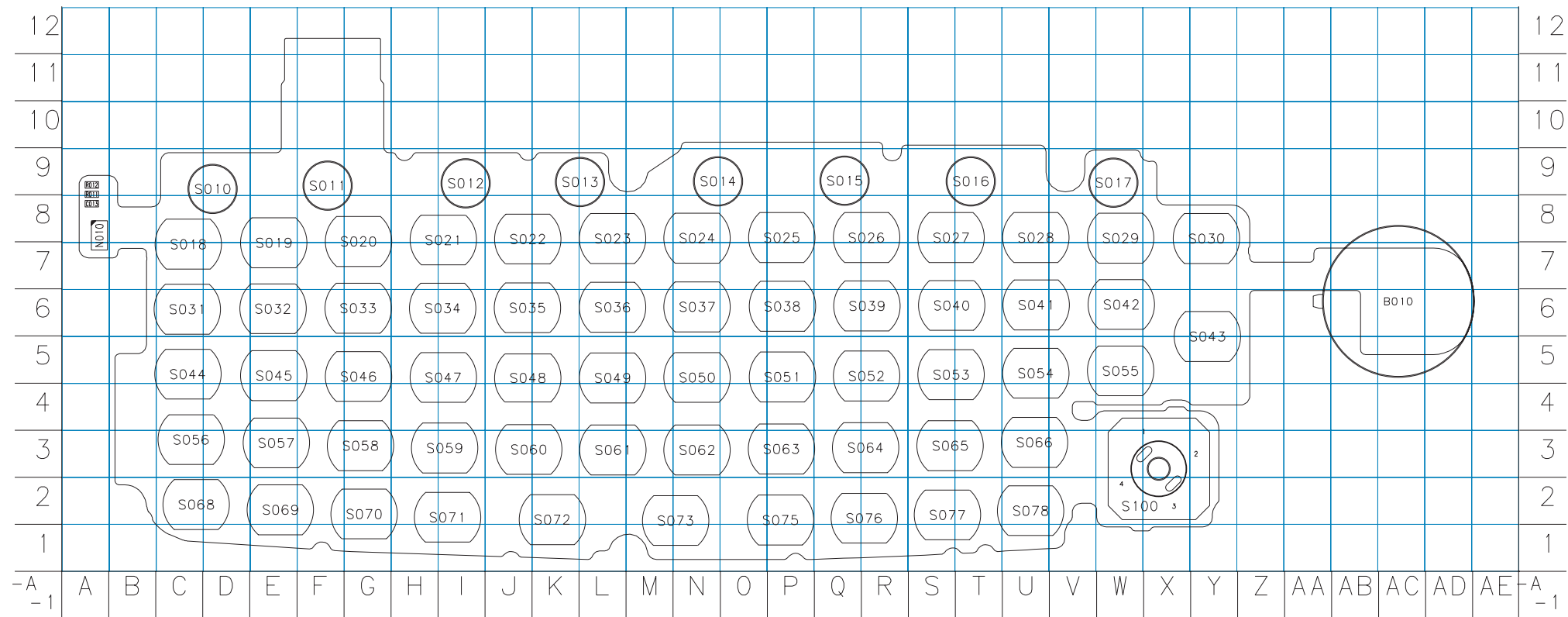

1cp\_09b

C
C100 D9
C101 D9
C102 Z12
C103 V14
C104 V14
C105 U14
C106 U14
C107 E9
C108 W14
C109 D7
C110 D8
C111 E8
C112 D8
C113 E8
C114 D8
D
D100 D7
D101 E7
L
L100 W14
N
N101 W14
N102 T14
N103 U14
R
R101 T14
R102 T14
R103 V14
R104 V14
R105 W9
R106 W11
S
S104 B13
S105 B11
S109 B9
S110 B8
S126 E12
V
V101 W11
V102 W9
V103 W14
X
X101 D8
X102 Y12

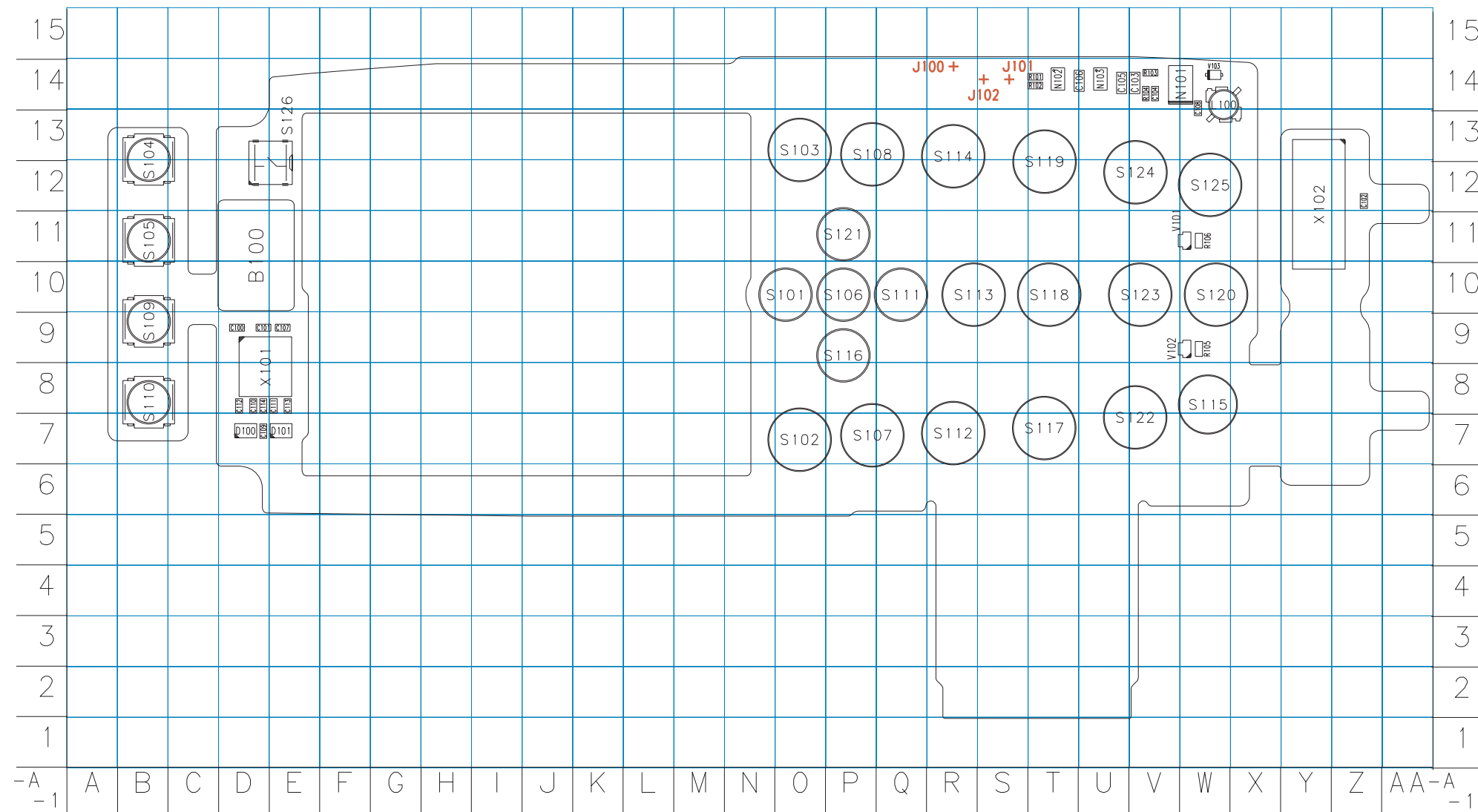

1bd\_10b

Component finder, engine module

B	C2026	L5	C2117	I9	C2216	F8	C2351	E7	C4104	G8	C4800	K7	C4819	E5	C6035	J8	C7510	D8	C7703	C3	D5000	J5	J2033	E6	J2809	F6	J4409	F2	J4810	J4	J6034	I7	L2001	K5	L6031	J9	N4800	G4	R2103	G6	R2353	G6	R4424	G4	R5202	H6	R7510	D7	T7700	D5	Z4402	F2		
B2200	G9	C2070	D3	C2118	G3	C2217	G8	C2353	G8	C4105	H8	C4801	K7	C4820	H4	C6036	J8	C7512	D9	C7704	D4	F5080	I3	J2060	I4	J2810	F6	J4410	F2	J4811	J2	J6035	I7	L2002	J4	L6032	I9	N5200	H7	R2104	K7	R2354	F7	R4425	G4	R6030	J8	R7511	D6	V	Z4403	F2		
B4800	J7	C2100	E7	C2119	I8	C2218	F7	C2700	B6	C4200	E5	C4802	J7	C5000	I6	C6038	K8	C7513	C6	C7705	C4	F	F2020	K5	J2121	J7	J2811	F7	J4411	E2	J4812	J2	J6036	I7	L2003	K7	L6033	I8	N6030	I8	R2105	K7	R2700	D6	R4427	G4	R6031	I9	R7512	C9	V2020	M5	Z6030	H9
C	C2101	D2	C2200	F9	C2219	E8	C2880	F6	C4201	G5	C4803	H3	C5001	I6	C6043	H8	C7514	D7	C7706	C6	G	G2400	D9	J2122	J7	J2813	F6	J4413	D9	J4814	J2	J7501	E7	L2005	J8	L7600	B7	N7700	C7	R2106	K7	R2900	E7	R4430	I3	R6034	I8	R7600	B6	V4200	C6	Z7600	B4	
C2000	D3	C2102	G7	C2201	G7	C2220	G9	C2881	F6	C4202	E5	C4804	H3	C5003	I5	C6044	I9	C7515	C6	C7708	E4	G	J2122	J7	J2813	F6	J4413	D9	J4814	J2	J7501	E7	L2005	J8	L7600	B7	N7700	C7	R2107	K7	R2901	E7	R4490	E8	R6039	J8	R7601	B6	V4400	F4	Z7601	B7		
C2001	D7	C2103	G7	C2202	G9	C2221	G7	C2882	E6	C4203	F4	C4805	H3	C5004	I6	C6045	I9	C7516	D7	C7709	D4	G2400	D9	J2700	C6	J2814	E7	J4414	D9	J4820	G5	J7502	F4	L2100	C2	L7601	B7	R	R2108	I9	R2902	E5	R4800	H6	R6040	K8	R7602	B7	V6030	K8	Z7602	B7		
C2002	D7	C2104	G6	C2203	G9	C2222	E7	C2883	E5	C4206	F4	C4806	H5	C5083	K3	C6046	I9	C7518	D6	C7710	D4	G7500	B9	J2701	D7	J2815	G6	J4415	K3	J4821	G4	J7503	F4	L2101	M6	L7602	B7	R2001	F9	R2109	H9	R2903	E7	R4801	K5	R6041	K8	R7701	C3	V6031	K8	Z7603	B6	
C2003	K6	C2105	L6	C2204	G6	C2223	E8	C2884	F6	C4207	E5	C4807	H6	C5084	K3	C6047	I8	C7519	B9	C7713	C4	G7501	D9	J2702	D6	J2816	F4	J4416	K3	J4822	G4	J7504	F4	L2110	G3	L7603	B7	R2002	K6	R2110	I9	R3000	E4	R4802	H4	R6042	K8	R7705	D3	X	Z7700	D6		
C2005	K4	C2106	K8	C2205	F6	C2224	E8	C2885	E5	C4208	D5	C4808	H5	C5085	K2	C6048	I9	C7520	D7	C7714	C5	J	J2703	D6	J2817	E6	J4417	K3	J4823	J7	J7505	F4	L2200	F8	L7604	B7	R2003	K5	R2111	J9	R4100	H8	R4803	H6	R6043	K8	R7707	D4	X2020	A4				
C2006	J3	C2107	K7	C2206	E7	C2225	E8	C2900	E7	C4209	E5	C4809	K6	C5086	K2	C6049	I9	C7600	B6	C7715	C4	J470	G4	J2704	D7	J2818	E6	J4800	I5	J4824	G5	J7506	F4	L2330	E8	L7701	C4	R2004	J4	R2112	J9	R4101	H7	R4804	H5	R6044	K8	R7710	D4	X2021	M6			
C2007	K4	C2108	K7	C2207	E7	C2226	E7	C2901	E7	C4211	E4	C4810	K4	C5087	K2	C7500	B8	C7601	B6	C7718	C6	J471	H4	J2800	G4	J4100	G9	J4801	K5	J4825	G5	J7507	E6	L2331	F8	N	R2006	K7	R2113	I8	R4202	D4	R4805	H7	R7500	A8	R7712	E4	X2060	K3				
C2008	K8	C2109	K7	C2208	E9	C2227	E8	C2902	E6	C4212	E4	C4811	K6	C5088	K2	C7501	B8	C7602	B6	C7719	C6	J472	H4	J2801	E6	J4101	G9	J4802	I5	J4826	H7	J7508	B8	L2332	E9	N2001	K3	R2007	J8	R2114	J8	R4401	G2	R4806	H4	R7501	C9	R7715	D3	X2700	C7			
C2009	J9	C2110	K8	C2209	E9	C2330	E8	C3030	E5	C4214	D4	C4812	K5	C5089	K2	C7502	B9	C7603	C4	C7721	D6	J473	H4	J2802	F6	J4102	H5	J4803	K6	J4827	J4	J7509	C8	L2333	E8	N2070	D3	R2008	I3	R2115	G3	R4410	D3	R4807	H6	R7502	C9	R7717	D4	X4401	H2			
C2010	J8	C2111	G8	C2210	E9	C2331	F8	C3031	E5	C4215	D4	C4813	H3	C5200	I6	C7503	B9	C7604	B5	D	J474	H4	J2803	F6	J4103	H5	J4804	K5	J4828	J4	J7510	C8	L2334	E8	N2100	J9	R2021	K2	R2116	H9	R4411	I2	R4808	J4	R7503	B8	R7718	G8	X4402	D2				
C2011	J8	C2112	G8	C2211	E9	C2332	E9	C3032	E4	C4403	I2	C4814	H3	C5201	G6	C7504	C9	C7605	B5	D2200	F8	J999	M4	J2804	D3	J4404	D2	J4805	I5	J4829	K3	J7511	C8	L2335	F7	N4100	H9	R2044	J3	R2117	I9	R4412	I2	R4810	F5	R7504	C9	S	X5200	I7				
C2012	J9	C2113	I9	C2212	E9	C2333	E9	C4100	G8	C4404	I3	C4815	I3	C5202	H6	C7505	C8	C7607	B7	D2800	F5	J2025	K5	J2805	E3	J4405	D2	J4806	J7	J6030	I7	J7512	C8	L4100	G8	N4200	F5	R2071	C3	R2200	F9	R4413	C2	R5000	K6	R7505	C7	S4400	F4	X7600	C4			
C2013	K8	C2114	I9	C2213	F9	C2334	E9	C4101	G9	C4408	C2	C4816	K4	C5203	H7	C7506	B8	C7700	C4	D4400	J2	J2026	K5	J2806	E3	J4406	D2	J4807	I5	J6031	I7	J7799	B9	L4201	C5	N4201	D4	R2100	E7	R2251	F8	R4419	D2	R5001	K5	R7506	C7	T	Z	Z	Z			
C2014	G4	C2115	I9	C2214	F9	C2335	F7	C4102	I9	C4490	E7	C4817	K5	C6031	I8	C7508	B8	C7701	B4	D4800	J5	J2027	K6	J2807	F6	J4407	G2	J4808	H5	J6032	I7	L	L4401	C2	N4202	E4	R2101	C2	R2350	F7	R4420	D2	R5200	H7	R7507	D7	T6030	I9	Z4400	G4				
C2015	B4	C2116	I9	C2215	G7	C2350	B4	C4103	I8	C4492	C9	C4818	H5	C6033	I8	C7509	D8	C7702	B3	D4801	F5	J2031	E3	J2808	G6	J4408	G2	J4809	I4	J6033	I7	L2000	K5	L6030	J9	N4490	C10	R2102	G6	R2352	G6	R4421	I7	R5201	I6	R7509	D7	T7500	C8	Z4401	D2			

